



**SISTEMA DE ENGANCHE REFORZADO ST5
MERCEDÉS BENZ® SPRINTER®
515 MINIBUS 19+1 2013->**



SE095

Las marcas y modelos utilizadas sólo a modo ilustrativo en este documento son propiedad de sus respectivos titulares legítimos

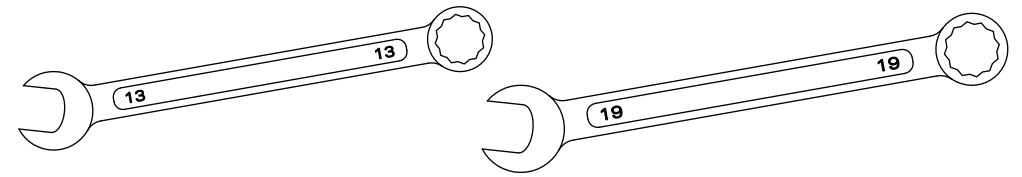

2. HERRAMIENTAS NECESARIAS

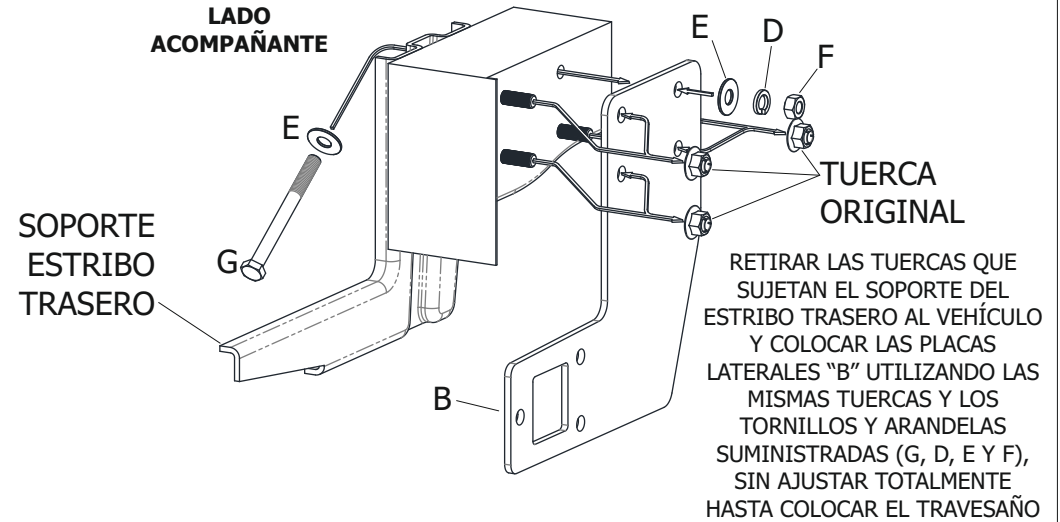

3. COLOCACIÓN DE PIEZAS "B"

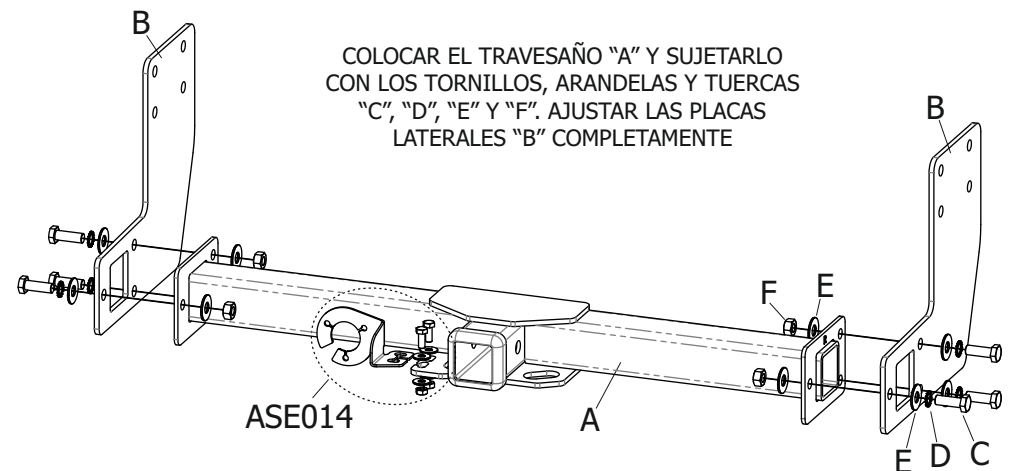

4. COLOCACIÓN DE PIEZA "A"

BSE001
M12P1.75
x35mm

BSE092
M12P1.75x130mm

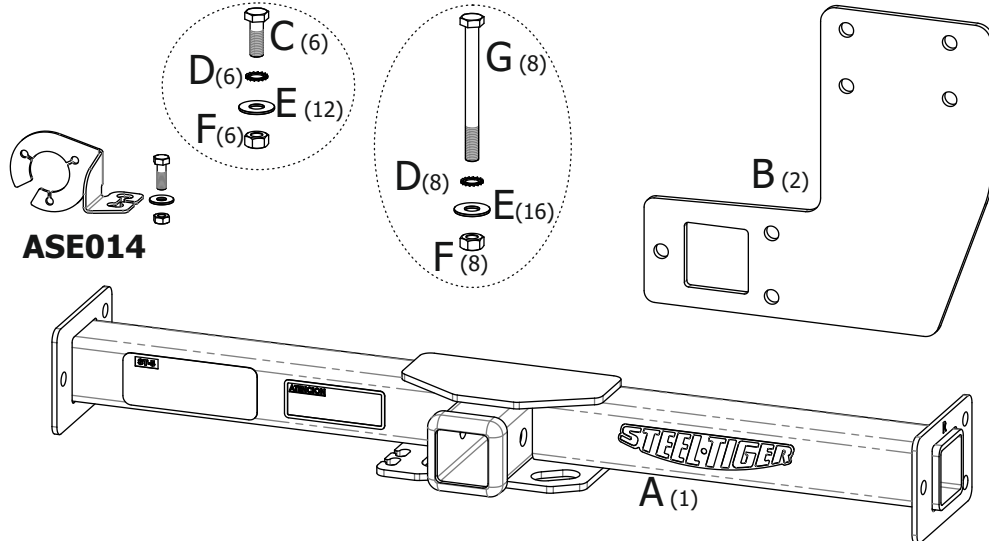

1. CONTENIDO