



SISTEMA DE ENGANCHE REFORZADO ST5 TOYOTA SW4 2016->



Las marcas y modelos utilizadas sólo a modo ilustrativo en este documento son propiedad de sus respectivos titulares legítimos

SE100

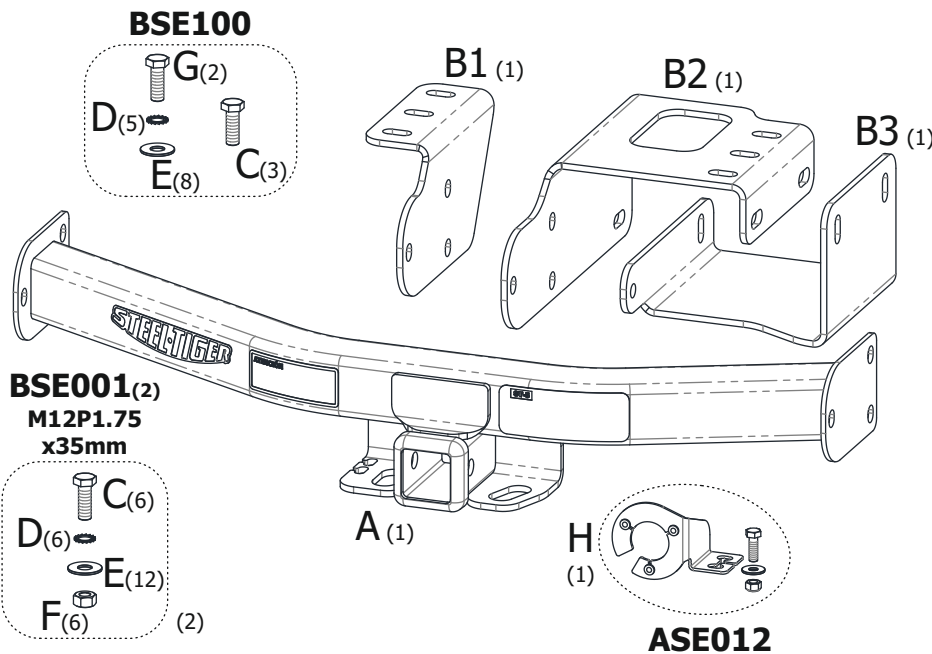

1. CONTENIDO



2. HERRAMIENTAS NECESARIAS

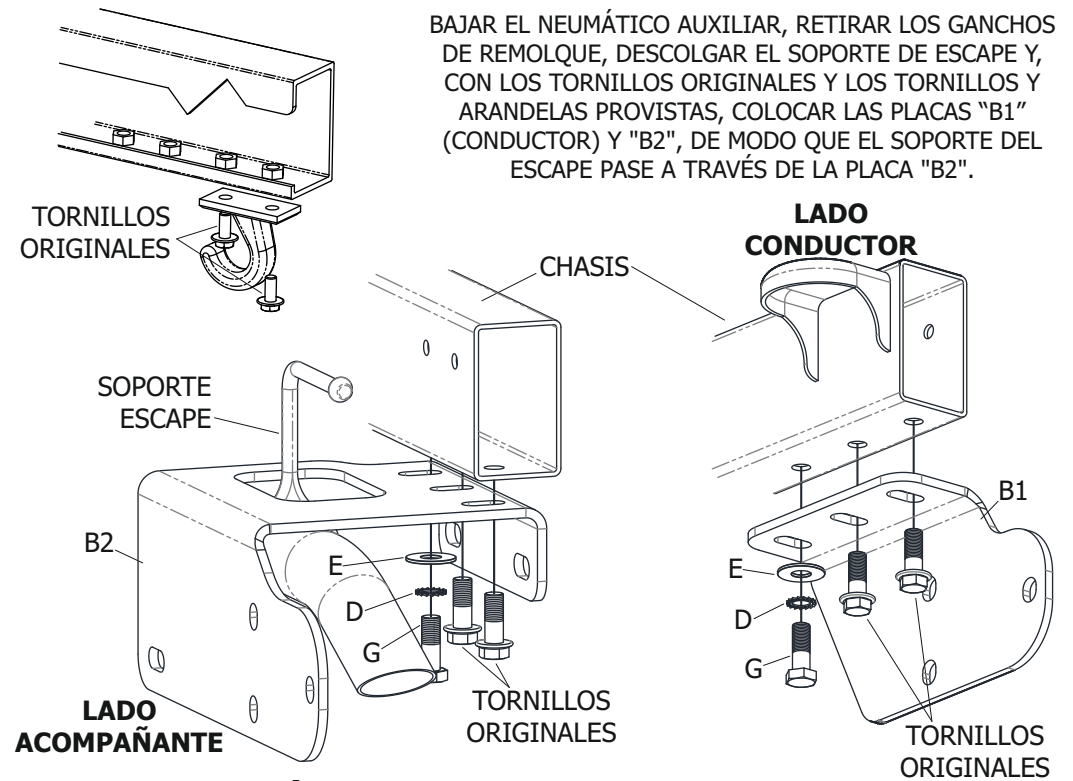

3. COLOCACIÓN DE PIEZAS "B1" Y "B2"

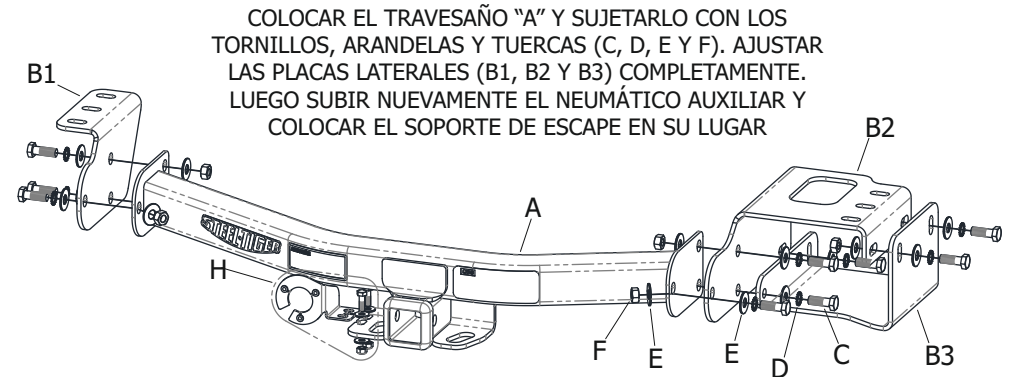

4. COLOCACIÓN DE PIEZA "A", "B3" Y "H"