

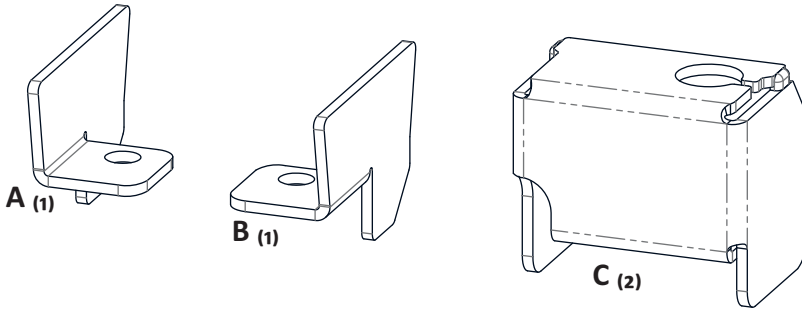

Las marcas y modelos utilizados sólo a modo ilustrativo en este documento son propiedad de sus respectivos titulares legítimos

ASP180

1. Contenido



Herramientas Necesarias



2. Instalación

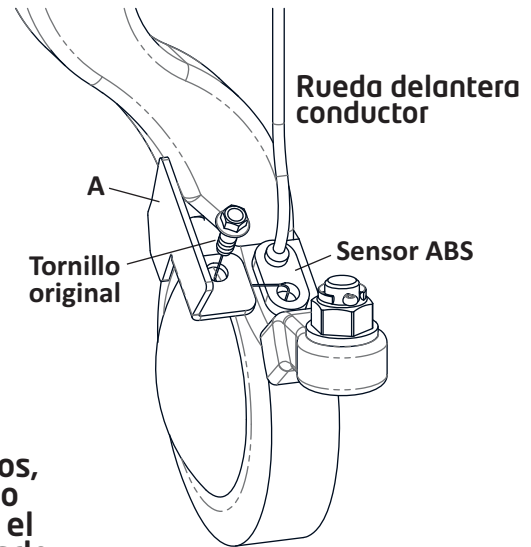
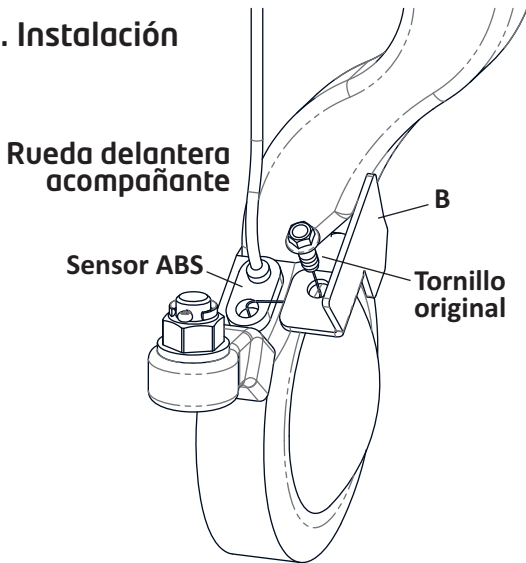

En todos los casos, retirar el tornillo original, colocar el protector y sujetarlo con el tornillo original, respetando el torque del mismo

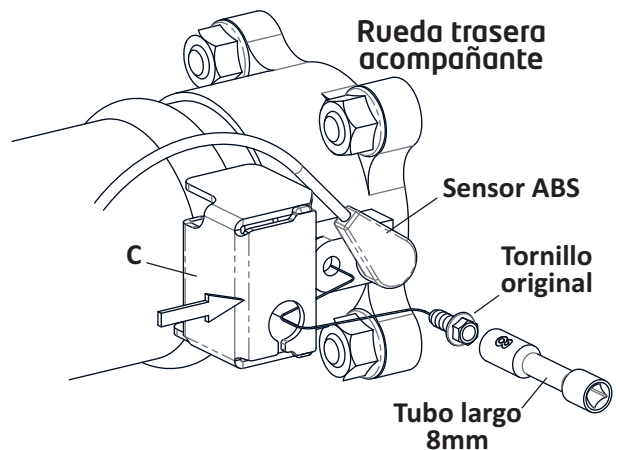
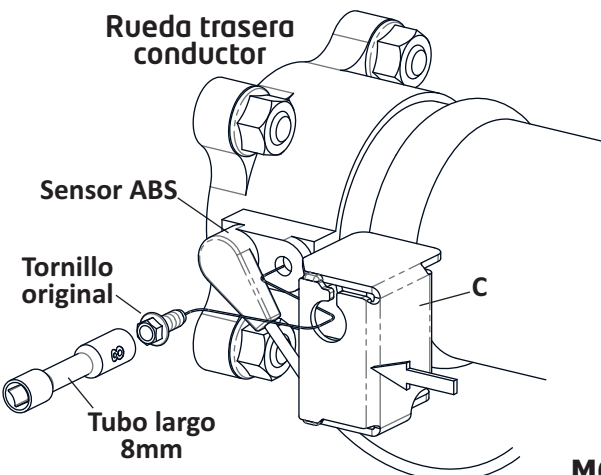

M6 Gr 8.8: 11 Nm