

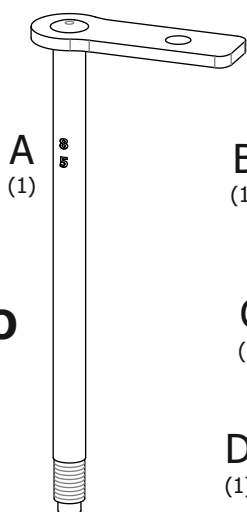

ASE085
KIT SEGURIDAD PARA NEUMÁTICO AUXILIAR
CHEVROLET® NUEVA S10®
MIDNIGHT 2018->
LLANTA 18x7½J - CUBIERTA 265/60R18

CONTENIDO



A
(1)

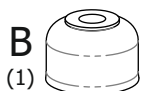

B
(1)

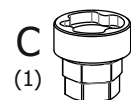

C
(1)



D
(1)

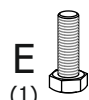

E
(1)



CÓDIGO
SEGURIDAD



CALCOMANÍA

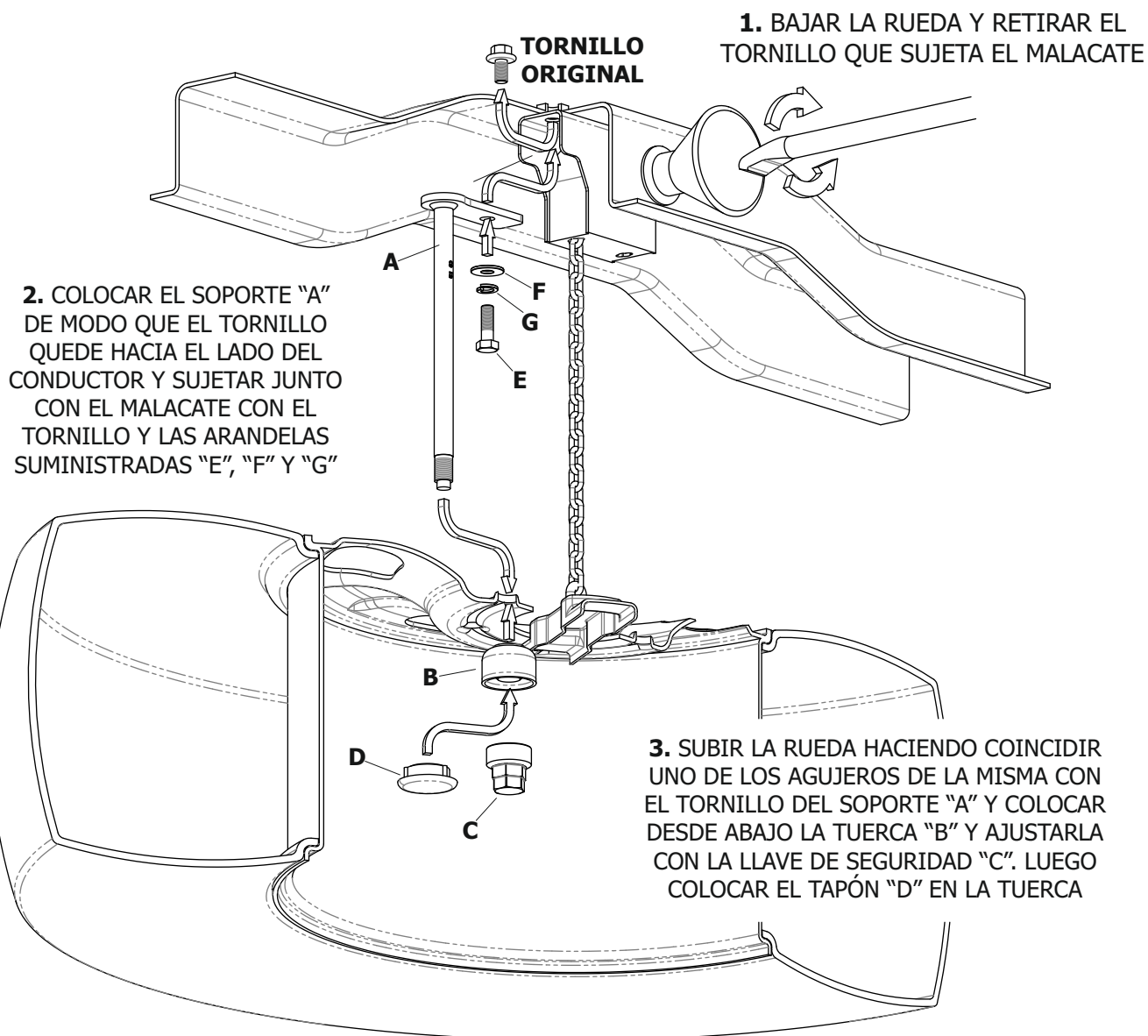

PRECAUCIÓN: GUARDAR LA LLAVE DE SEGURIDAD EN EL BOLSO PORTAHERRAMIENTAS Y, EN CASO DE PÉRDIDA, SOLICITAR UNA NUEVA MEDIANTE EL CÓDIGO IMPRESO EN LA TARJETA



ADHERIR LA CALCOMANÍA EN UN LUGAR VISIBLE (PARAGOLPES, PORTÓN TRASERO, LUNETA, ETC.)